

Side protection systems

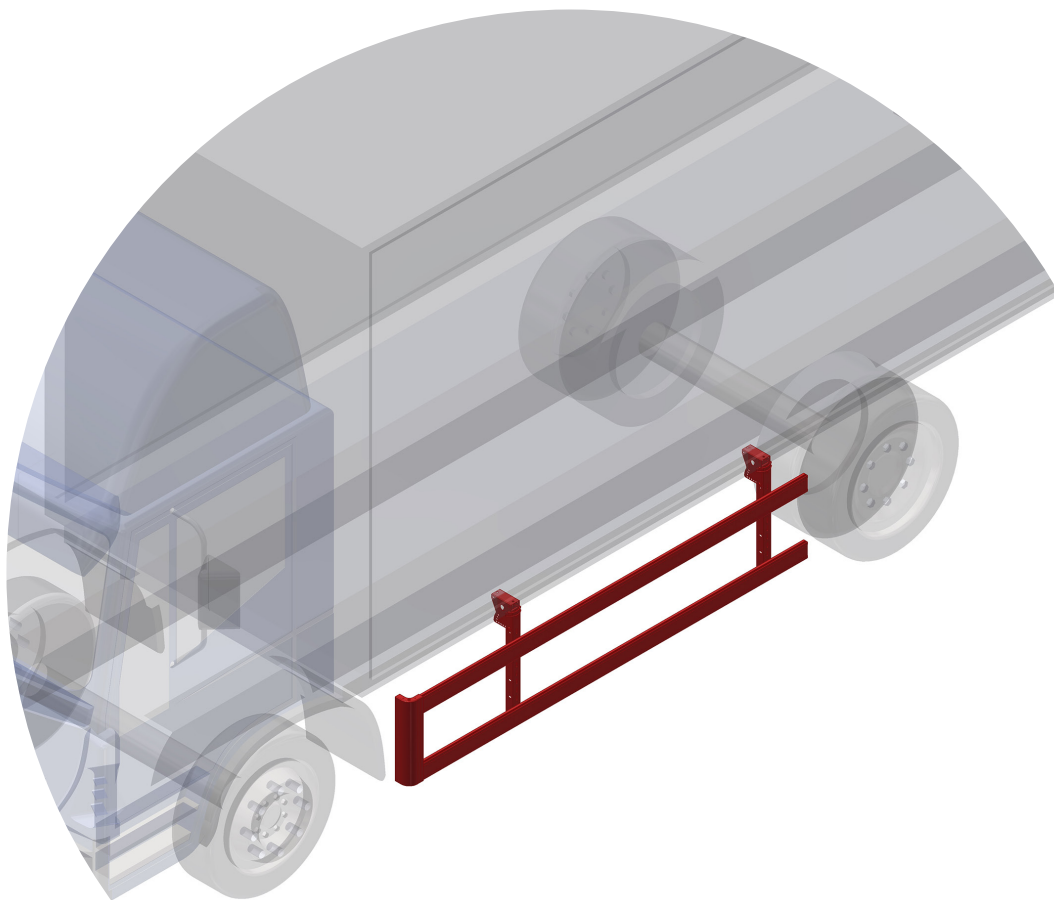

Option with plastic corner H1



TRANS-TECHNIK

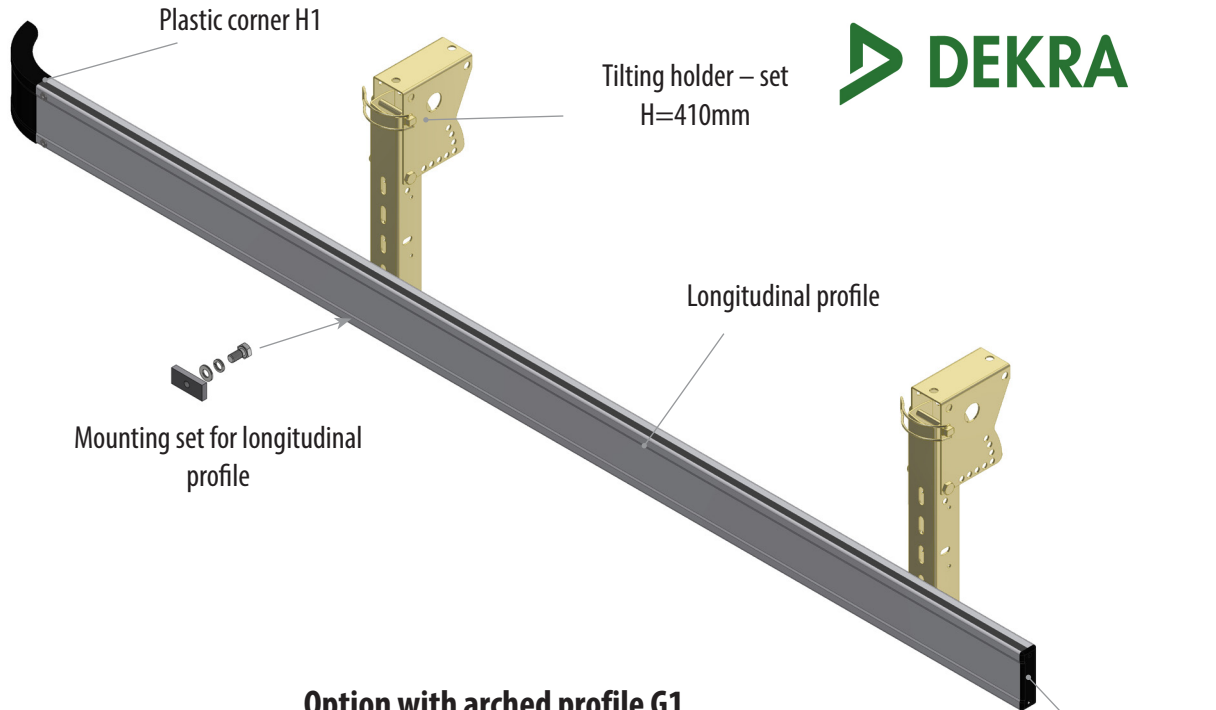

Option with arched profile G1

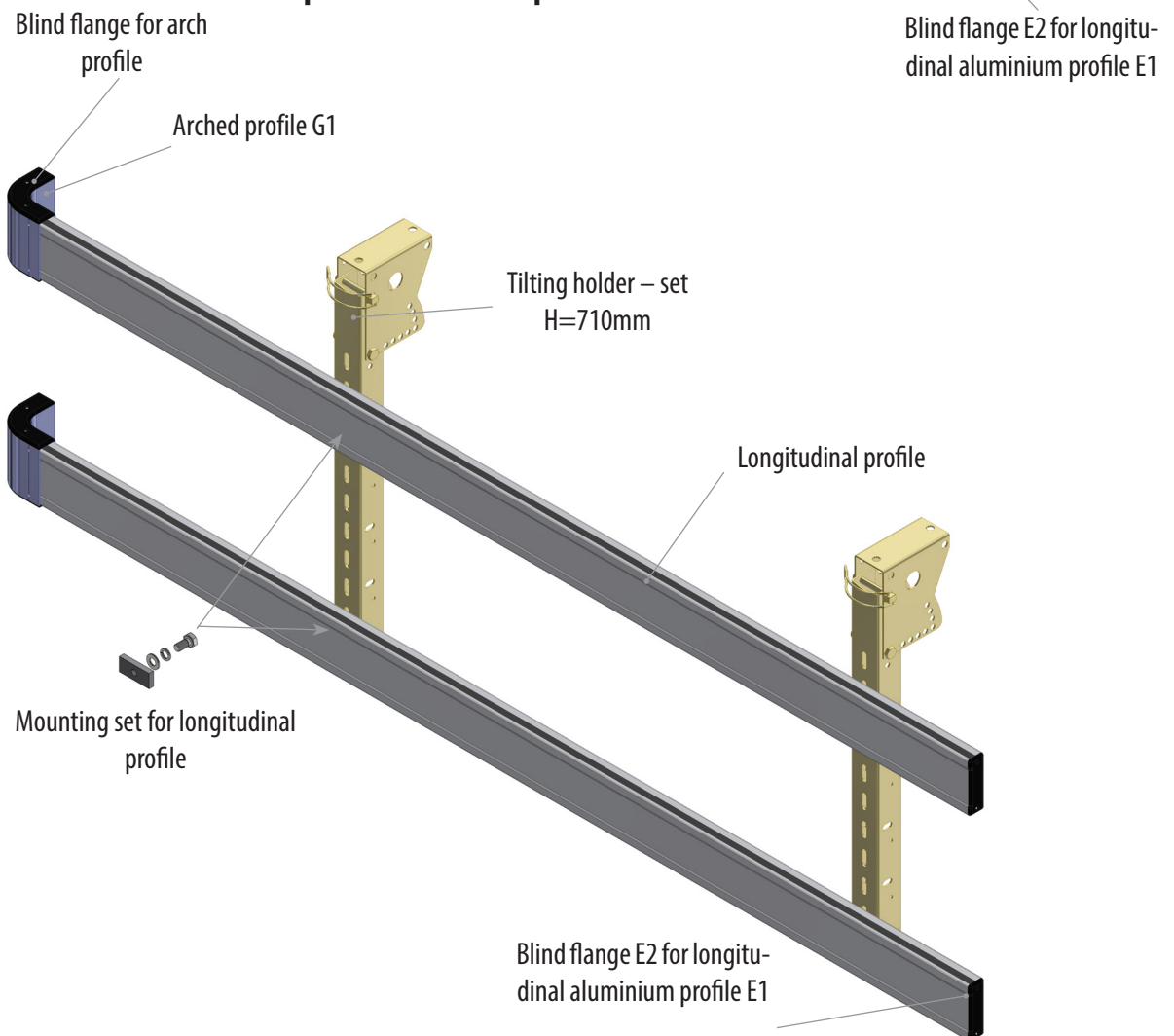

New side protection holders with Magnelis surface treatment

0811 045.410

Tilting holder – set

H=410 mm

Material: steel-surface Magnelis

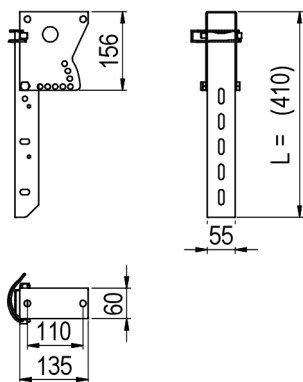
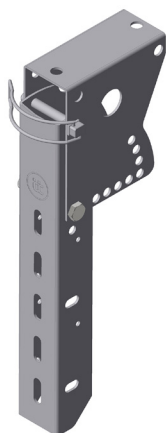

0811 045.710

Tilting holder – set

H=410 mm

Material: steel-surface Magnelis

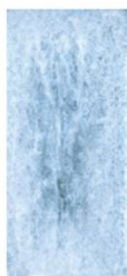
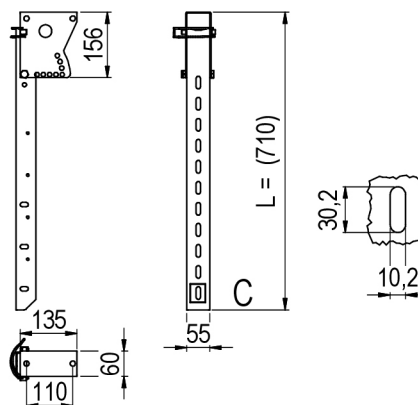
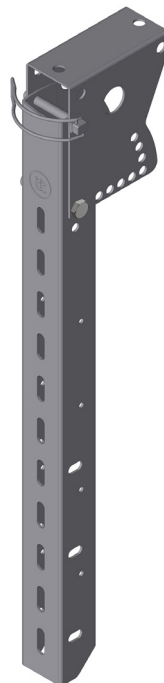

Magnelis
po 34 týdnech

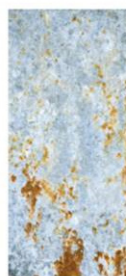

ocel pozink
po 34 týdnech



galvan. pozink
po 7 týdnech

Benefits of Magnelis

Magnelis metal coating offers protection against the most challenging conditions.

Chemical composition of Magnelis is optimized in order to provide highest rust protection.

The composition of the galvanization bath is improved. Zinc bath has different chemical composition: 3,5% of aluminium and 3% of Magnesium. Magnesium is key factor, it creates stable and resistant layer on the surface. Compared to coating with less magnesium more efficient corrosion resistance is achieved. As a result, Magnelis is more effective compared to standard zinc plating.

Side protection system consists of these parts

Longitudinal profile E1

Material: Al

Weight: 1,08 kg/m

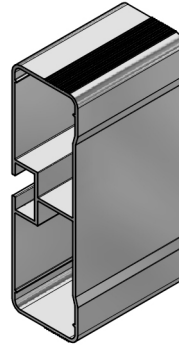
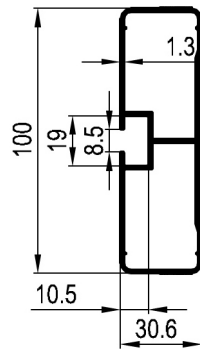

TT-number

0811 018.000 - Al elox

0811 019.000 - Al přírodní

Blind flange E2 for longitudinal aluminium profile E1

Material: plastic black

Weight: 0,05 kg/pc

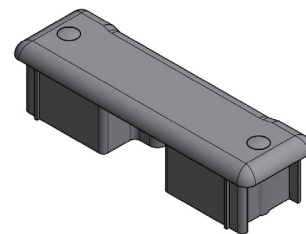
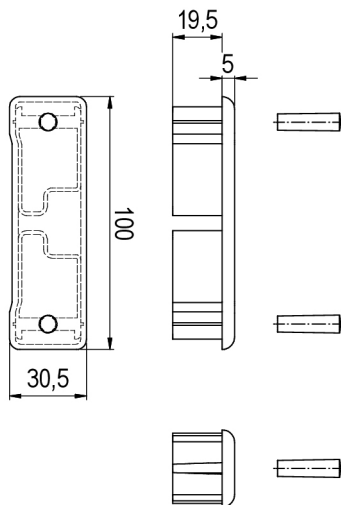

TT-number

0811 013.100

Plastic corner H1

Material: plastic black

Weight: 1,08 kg/m

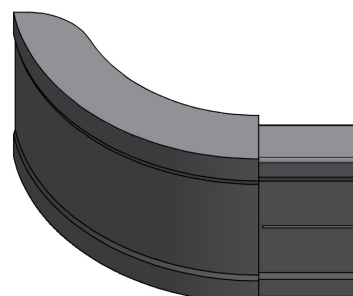
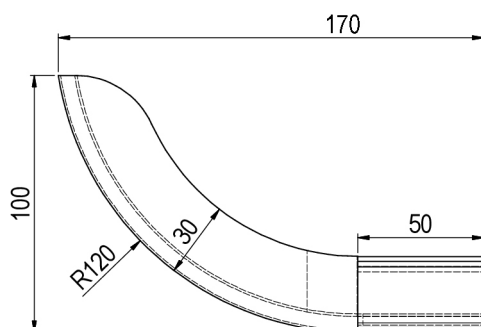

TT-number

0811 011.100

Arched profile

G1 Material: Al
Weight: 1,08 kg/m

TT-number

- 0811 010.001 - L = 100mm
- 0811 010.036 - L = 360mm
- 0811 010.005 - L = 500mm
- 0811 010.050 - L = 5000mm

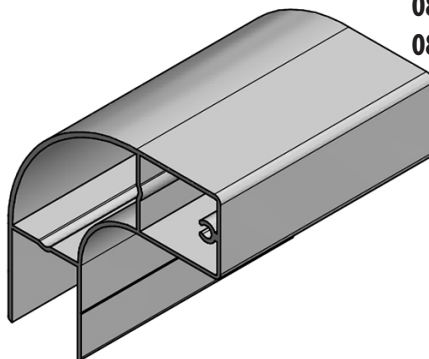
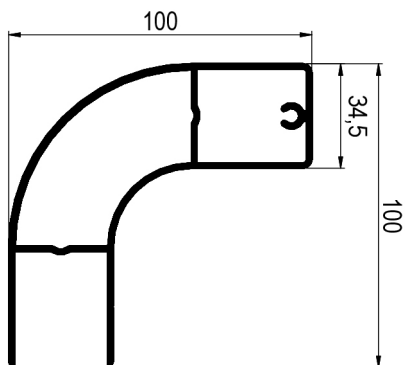

Blind flange for arched profile

Material: plastic black Weight: 0,08 kg/m

TT-number

0811 012.100

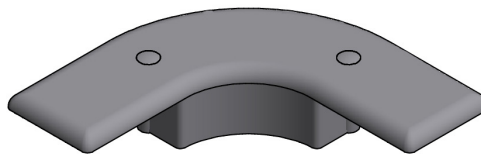
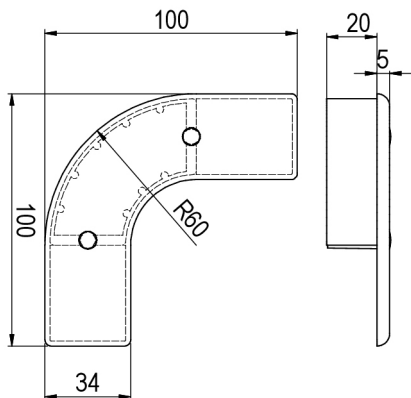

Mounting set for longitudinal profile

Material: galvanized steel
Weight: 0,05 kg/ks

TT-number

0811 017.000

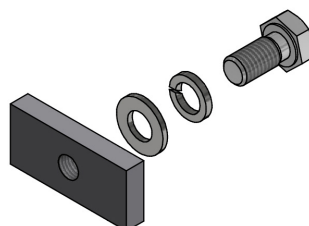
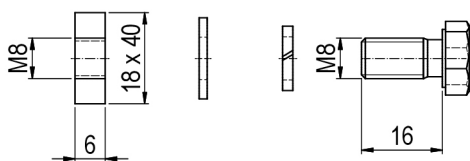

Approval sticker location

System is approved as a set

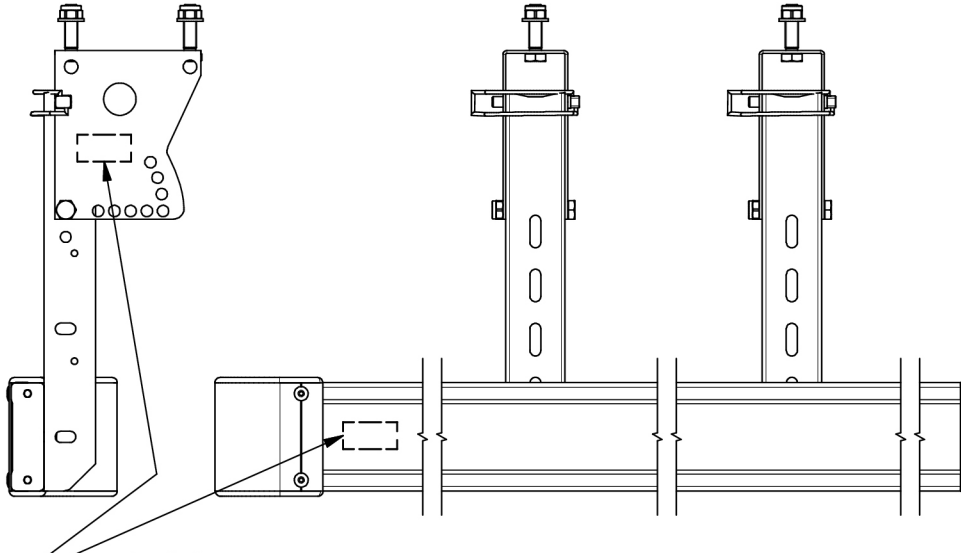

Location of approval label





TRANS – TECHNIK spol. s.r.o.
Tyršova 1146, Modřice, 664 42, Česká republika

+420 548 424 039
objednavky@trans-technik.cz

IČO: 44016077
DIČ: CZ44016077